

1 OUNCE FUEL TANK  
.049 TEE DEE or NORVEL  
.061 BIG MIG SPORT

USUAL DOPE FINISH  
CLEAR, THEN COLOUR

CLOTH HINGES

1/8" PLYWOOD LEADOUT GUIDE  
AND STIFFENER BRACE

.025 WIRE LEAD-OUTS

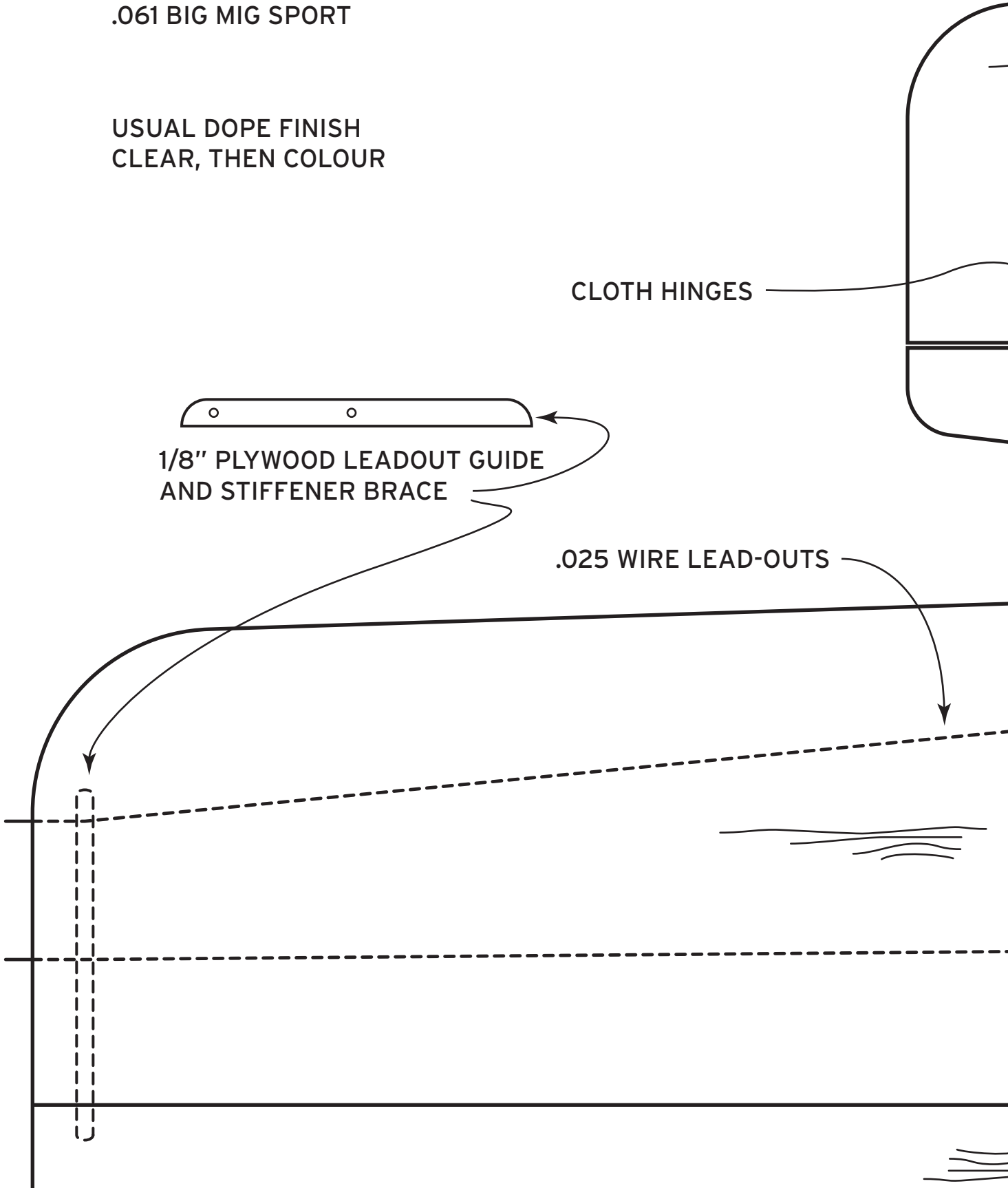

FLY THIS MODEL ON 35' TO 40' STRANDED  
OR "SPYDERWIRE" LINE.

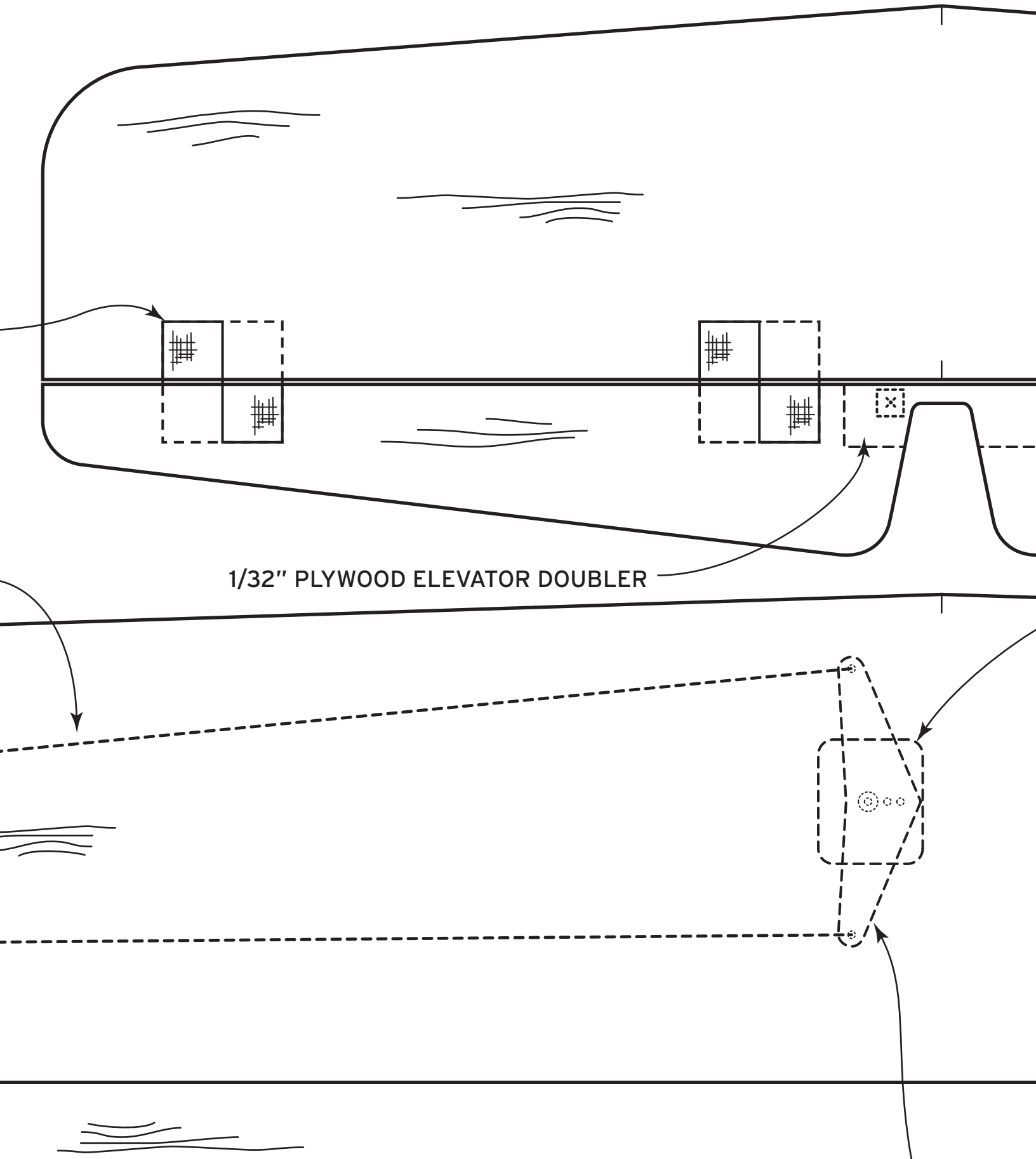

1/32" PLYWOOD ELEVATOR DOUBLER

BRANDED .008 CABLE LINES FOR STUNT  
"E" LINES FOR SPORT

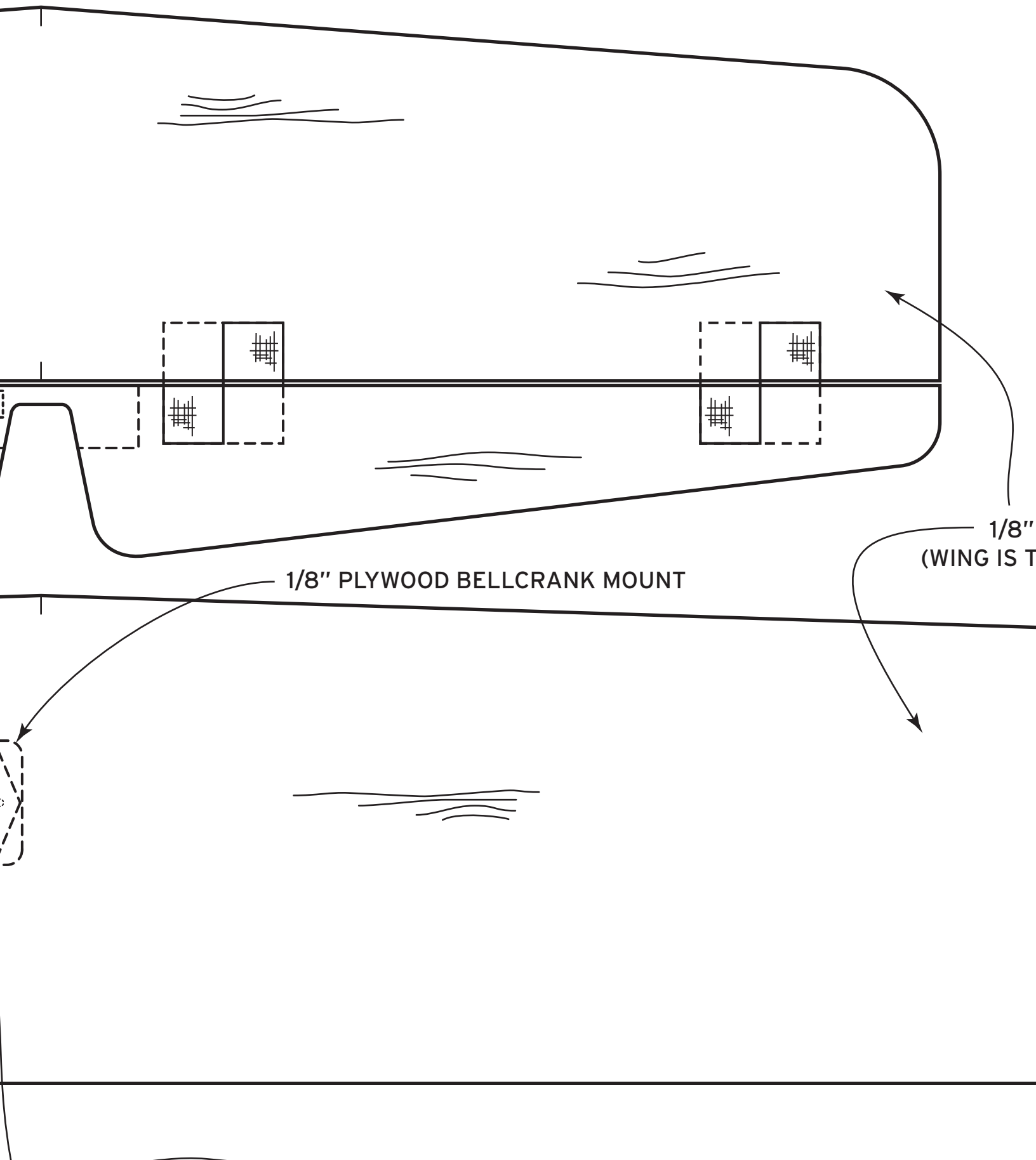

1/8" PLYWOOD BELLCRANK MOUNT

1/8"  
(WING IS T

USE MEDIUM TO LIGHT WOOD  
FOR ALL BALSA

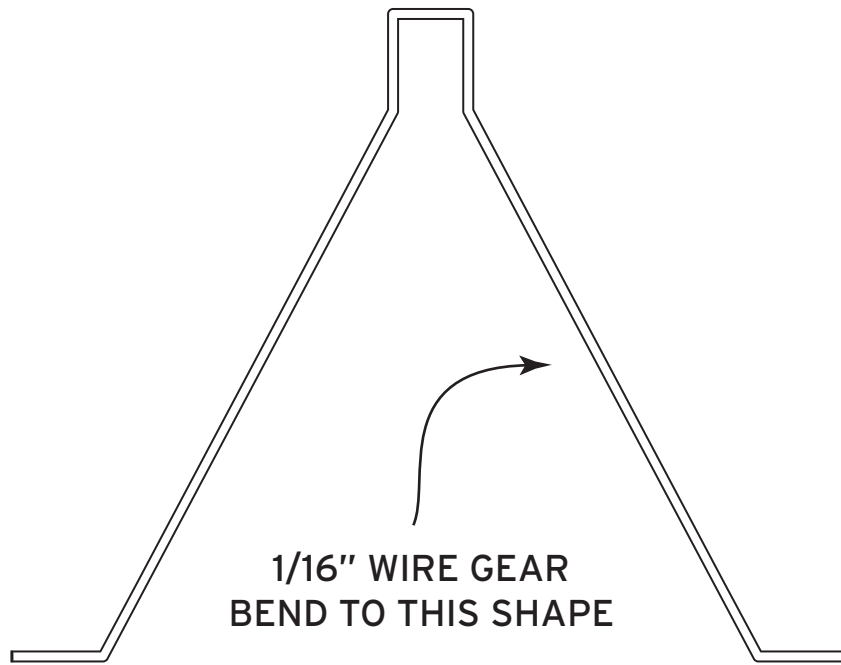

1/8" Balsa WING & TAIL SURFACES  
(WING IS TWO SHEETS EDGE GLUED TOGETHER)

WINGTIP  
WEIGHT

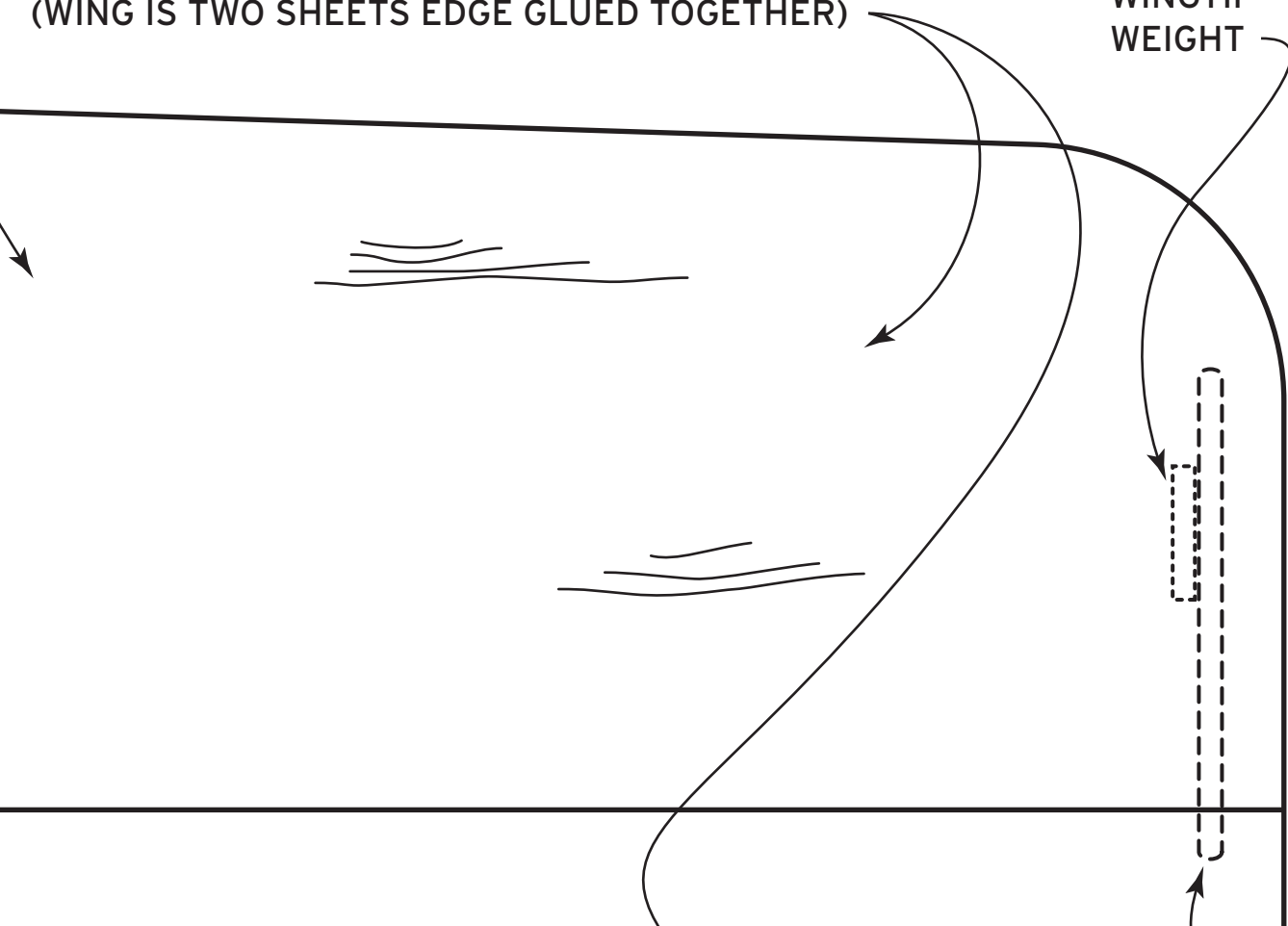

WIRE HOOK FOR FUEL TANK RUBBER BAND MOUNTING

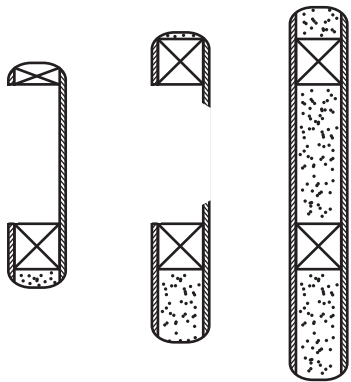

A B C

FUSELAGE CROSS SECTIONS

SMALL OPENING FOR CRANKCASE CLEARANCE

1/4" SQUARE HARDWOOD ENGINE MOUNT

1/32" P

A B C

A B C

1/16" WIRE GEAR

1" WHEEL & GEAR (OPTIONAL)

28" WINGSPAN  
21 1/4" LONG

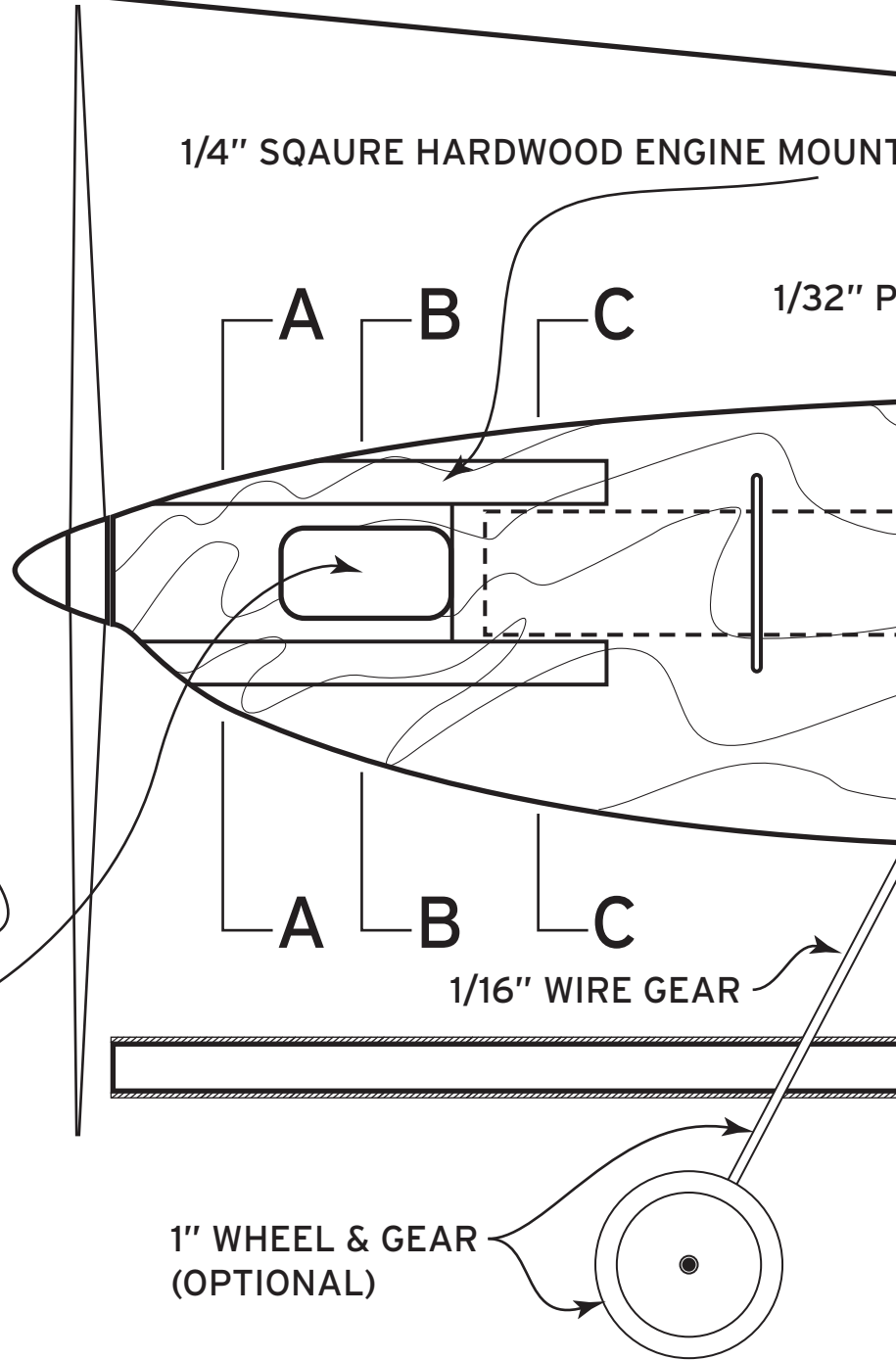

ENGINE MOUNTS (MAPLE)

2 3/8" NYLON BELLCRANK

1/32" PLYWOOD FUSELAGE DOUBLERS

PAINTED ON CANOPY

1/4" I

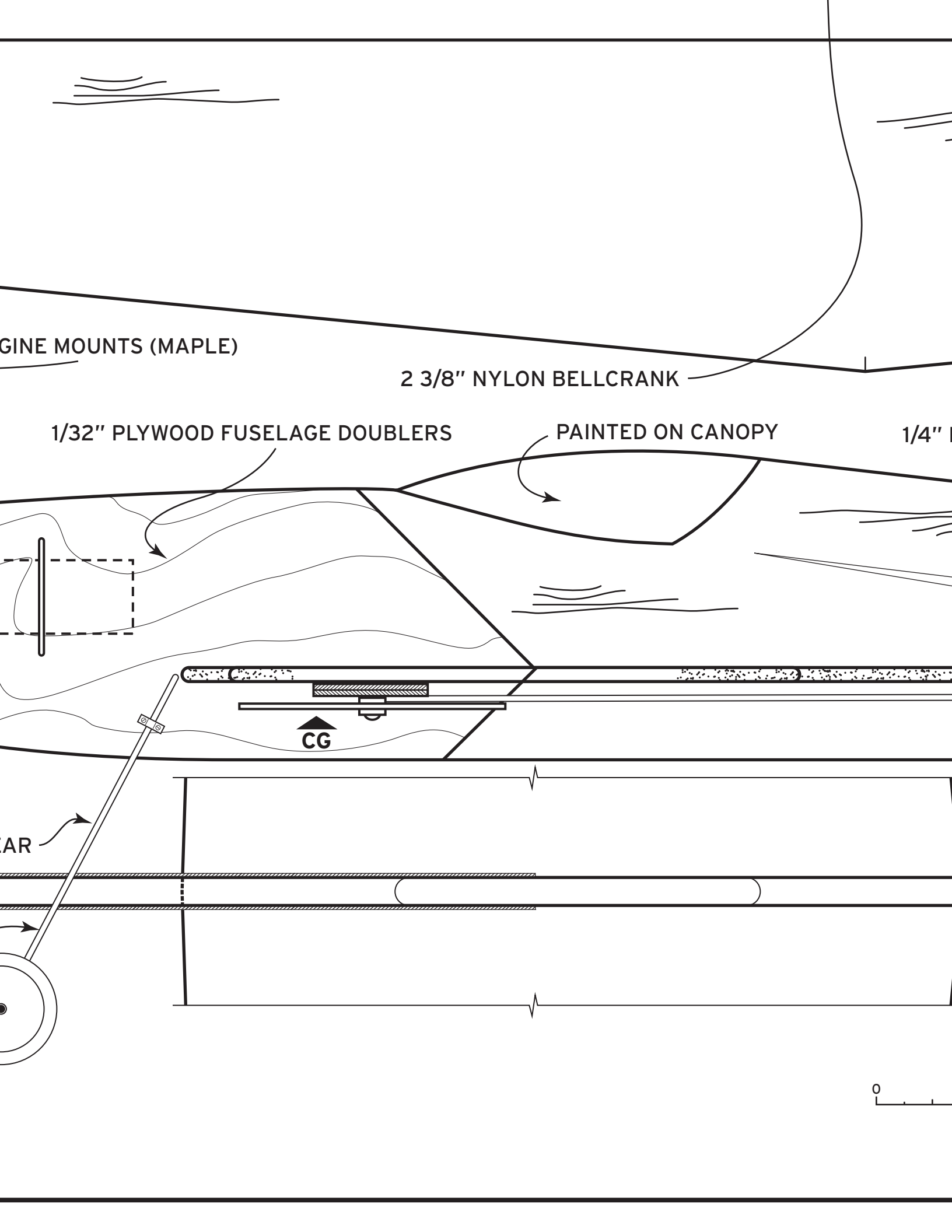

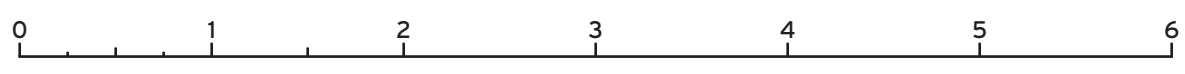
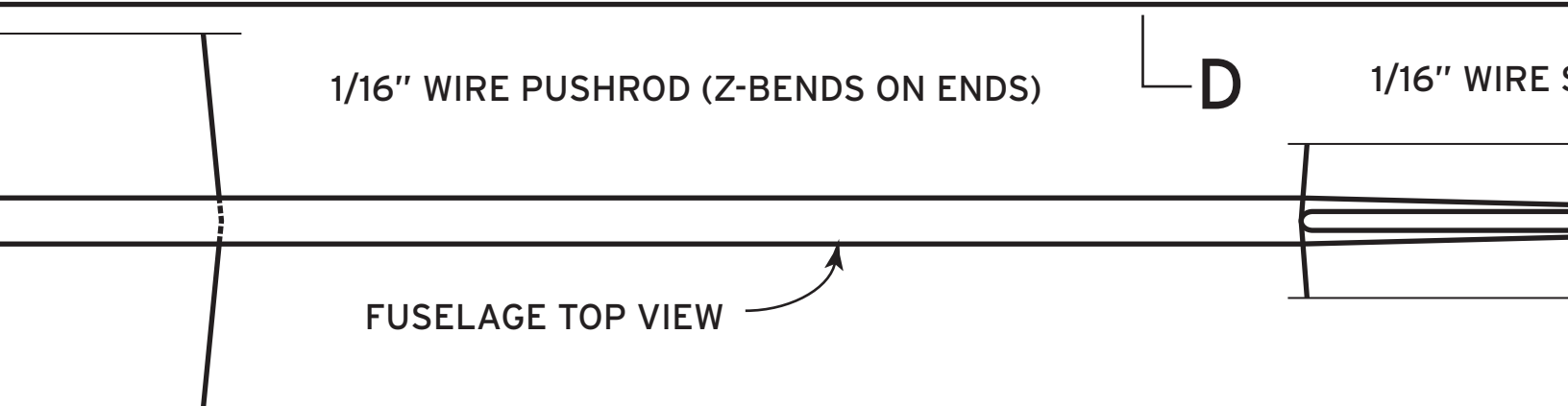
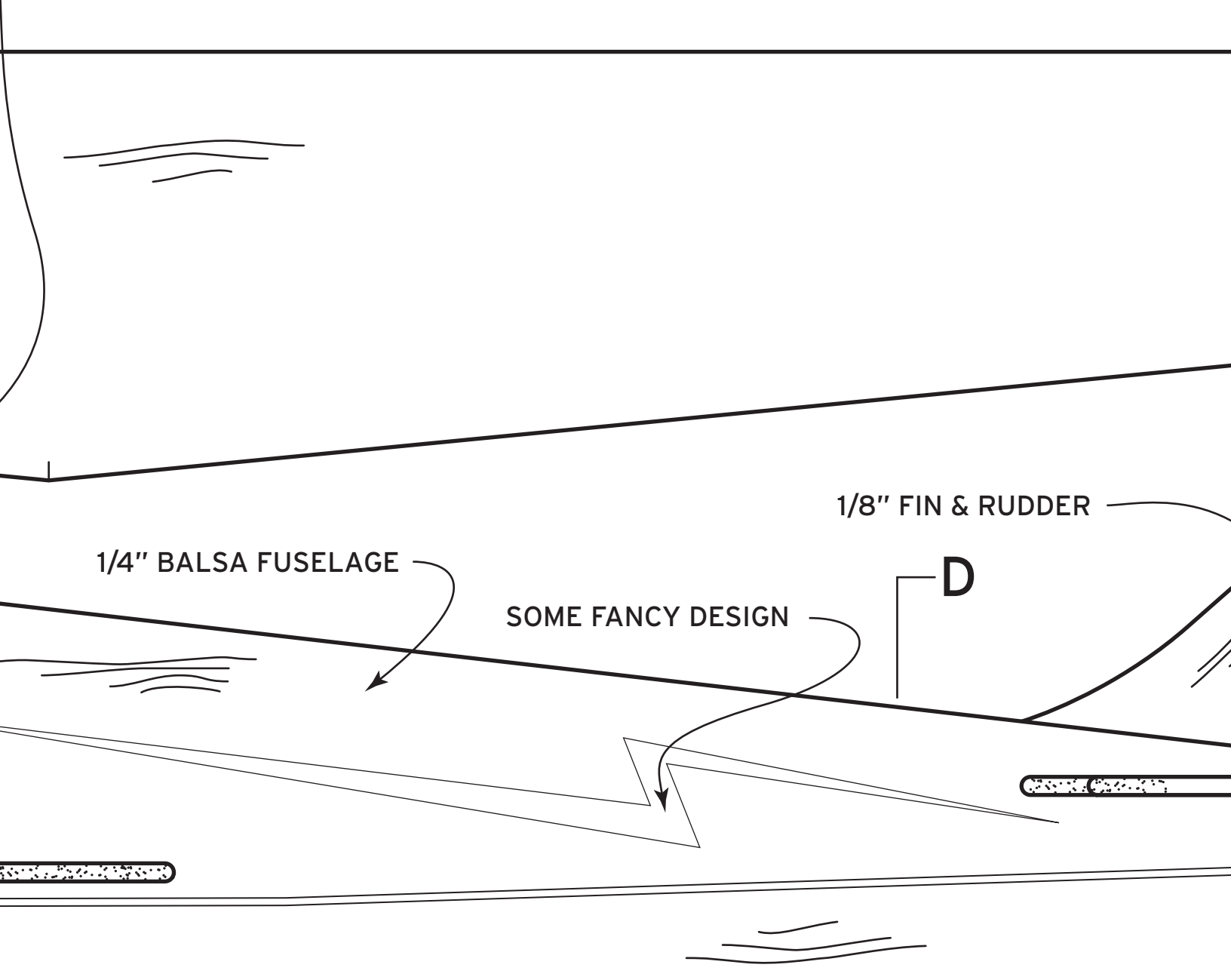

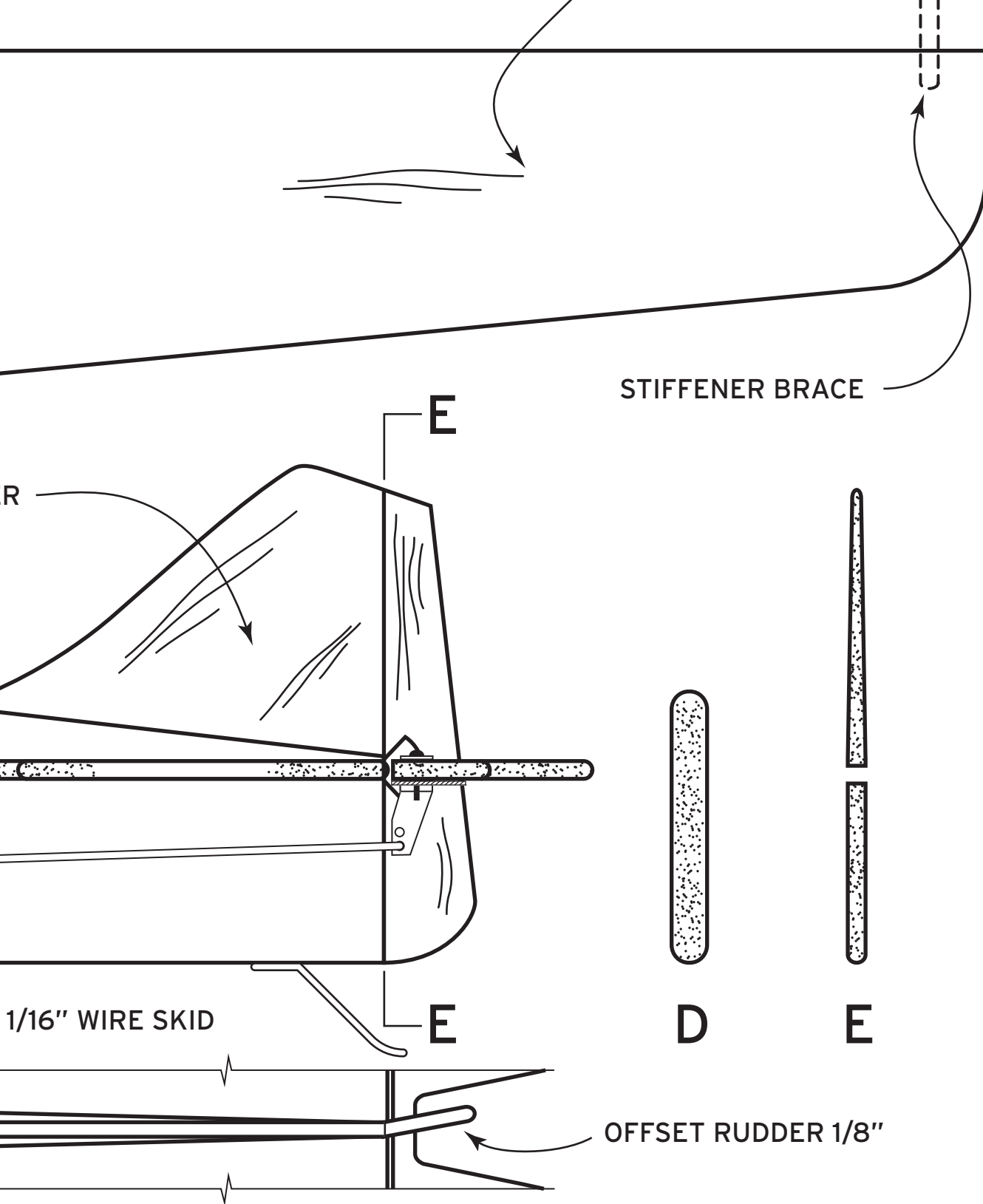

# WHITE LIGHTNING

1/2A PROFILE STUNT/SPORT

A CONTROL LINE AIRPLANE FOR .049 - .061

[www.hippocketaeronautics.com](http://www.hippocketaeronautics.com)

Copyright©2005, B. Feaver/Hip Pocket Aeronautics